

# SMART DIFFERENTIAL PRESSURE TRANSMITTER

## for low ranges APRE-2000G

min. range  
**0.2 mbar**

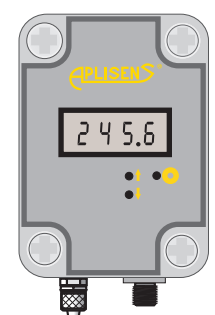
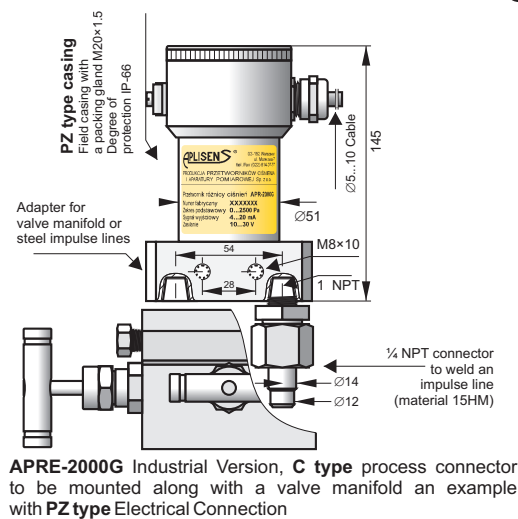

**APRE-2000G/N wall-mounted version with display and local keys allowing programming, process connection PCV type.**  
Dimensions: width: 80, height: 110, depth: 67

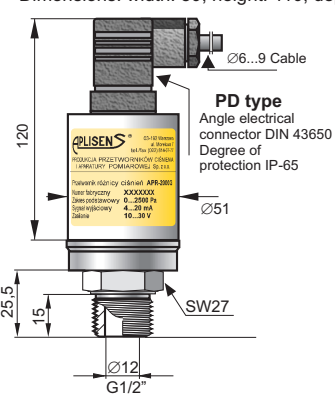
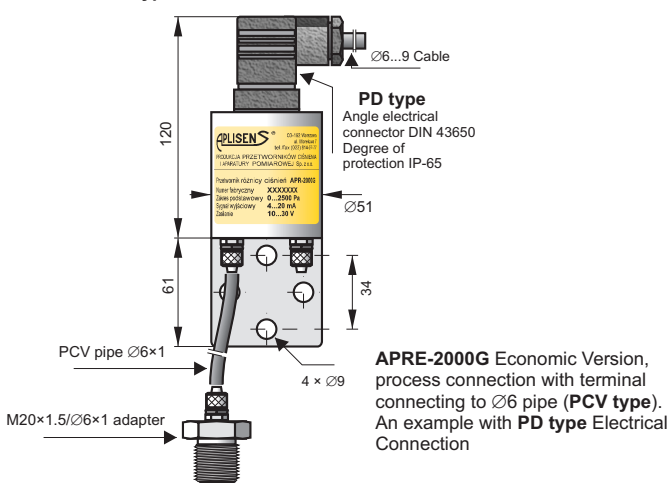

**APRE-2000G Economic Version, process connection G1/2" or M20 thread (Version with addapter GP or P... type). (Designed to measure relative pressure)**

- ✓ Programmable range, zero shift, damping ratio and characteristic
- ✓ 4...20 mA output signal + HART protocol
- ✓ Accuracy from 0.1%
- ✓ ATEX Intrinsic safety (only APRE-2000G/PD, APRE-2000G/PZ)

### Application

The APRE-2000G transmitter is applicable to gases, to the measurements of their pressure, underpressure and differential pressure. Typical applications include the measurement of blast pressure, chimney draughts or pressure / underpressure in furnace chambers. The ability to select the radical conversion characteristics enables the transmitter to be used in gas-flow measurement systems using reducing pipes or other impeding elements. The transmitter can withstand overpressure up to 1 bar. The housing of the electronic circuit has the degree of protection IP65, IP66, IP67.

### Configuration, calibration

- The following metrological parameters can be configured:
- ◆ The units of pressure,
  - ◆ Start and end-points of measuring range, damping time constant,
  - ◆ Conversion characteristic (radical, inversion, user's non-linear characteristic).
- Ability to calibrate the transmitter with reference to a standard pressure.

### Communication

Communication with the transmitter is carried out with a KAP-03 communicator, some other Hart communicators or a PC with an Hart/USB/Bluetooth converter and RAPORT 2 configuration software.

Additionally, the data interchange with the transmitter enables the users to identify the transmitter, read the currently measured pressure difference value, output current and percentage of measuring range.

### Installation

The economical version can be mounted on any stable construction using the assembly fixture with Ø9 opening. The transmitter's connection shanks have terminals to be connected to the elastic Ø6x1 impulse line. Where the pulse comes through a metal pipe, we suggest an M20x1.5 adapter for a Ø6x1 fitting using.

The transmitter with a C type connector should be mounted on a 3- or 5-valve manifold. We recommend the use of our pre-assembled transmitters with VM type valves (page IV/ 2).

## Operating guidelines

The transmitter should be mounted in a vertical position. The impulse lines should be connected in such a way that any condensed liquids flow off away from the device.

Where there is a significant difference in height between the place where the transmitter is mounted and the place where the pulse is taken, the measurement may vary with the temperature of the impulse line. Connecting a compensating pipe close to the impulse line, from the transmitter's reference connection shank to the height at which the impulse is taken can minimise this effect.

To prevent dust from entering the measuring cells, the impulse lines should be attached with care, with particular attention to the tightness of the connections between the impulse lines and the transmitter.

## Measuring ranges

Nominal measuring range (FSO)	Minimum set range	Overpressure limit	Static pressure limit
0...25 mbar (0...2500 Pa)	1 mbar (100 Pa)	1 bar	350 mbar
-2.5...2.5 mbar (-250...250 Pa)	0.2 mbar (20 Pa)	350 mbar	350 mbar
-7...7 mbar (-700...700 Pa)	1 mbar (100 Pa)	350 mbar	350 mbar
-25...25 mbar (-2500...2500 Pa)	5 mbar (500 Pa)	1 bar	1 bar
-100...100 mbar (-10...10 kPa)	20 mbar (2 kPa)	1 bar	1 bar

## Meterological parameters

Nominal range	0...25 mbar	-2.5...2.5 mbar	-7...7 mbar	-25...25 mbar	-100...100 mbar
Accuracy	0.075%	0.16%	0.1%	0.1%	0.075%

**Thermal error**  $\leq \pm 0.1\%$  (FSO) / 10°C  
 max.  $\pm 0.4\%$  (FSO) in the whole compensation temperature range  
**Thermal compensation range** -10...70°C  
**Time Constant** 0,3 s  
**Additional electronic damping** 0...60 s

**Error due to supply voltage changes** 0.002% (FSO) / V

### Electrical parameters

#### Power supply

APRE-2000G/PD and PZ: 7,5...55V DC (EEx 7,5...28 V)  
 APRE-2000G/N: 12...36V DC (additional voltage drop when display illumination switched on: 3V)

**Output signal** 4...20 mA, two wire transmission

$$\text{Load resistance } R[\leq] \leq \frac{U_{\text{sup}}[\text{V}] \leq U^{**}}{0,02\text{A}} \leq 0.85 \leq$$

U\*\* different voltage for each version  
 APRE-2000G/PD and PZ: 7,5 V DC  
 APRE-2000G/N: 12 V DC

**Resistance required for communication** 240...1100  $\leq$

### Operating conditions

**Operating temperature range (ambient temp.)** -25...85°C

### Materials

APRE-2000G/PD and PZ  
 Materials: casing 304ss  
 adapter C type 316ss  
 adapter PCV type (on  $\leq 6$  elastic pipe) brass  
 valve manifold 316ss  
 APRE-2000G/N  
 Materials: casing plastic box

## Electrical diagram

APRE-2000G/N APRE-2000G/PZ APRE-2000G/PD

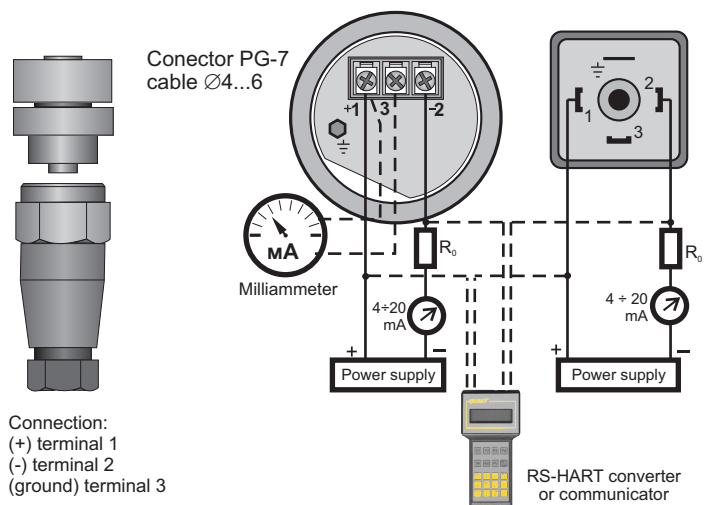

## Ordering procedure

Model	Code	Description	
APRE-2000G		Smart differential pressure transmitter.	
Certificate	/EEExia.....	Ex II 1/2G Exi IIC T4/T5/T6 Ga/Gb, I M1 EEExia I Ma Ex II 1D Ex ia IIIC T110C Da	
Casing, Output signal,	≤ /PD.....	Housing IP65 with DIN43650 connector, without display, output 4–20mA +Hart.	
	/PZ.....	304SS housing, Ip66, without display, output 4–20mA + Hart packing gland M20x1,5	
	/N.....	Housing IP65, electrical connector PG-7 (ATEX version not available ),	
Nominal measuring range		Range	Min set range
	/0÷25mbar.....	0÷25mbar (0÷2500Pa)	1mbar (100Pa)
	/-2.5÷2.5mbar.....	-2.5÷2.5mbar (-250÷250Pa)	0.2 mbar (20Pa)
	/-7÷7mbar.....	-7÷7mbar (-700÷700Pa)	1mbar (100Pa)
	/-25÷25mbar.....	-25÷25mbar (-2500÷2500Pa)	5mbar (500Pa)
	/-100÷100mbar.....	-100÷100mbar (-10÷10kPa)	20mbar (2kPa)
Measuring set range	/...≤... [ required units].....	Calibrated range in relation to 4mA and 20mA output	
Process connections	≤ /PCV.....	Process connection with terminal connecting for Ø6mm elastic pipe Mounting bracket for wall mounting is a standard.	
	/C.....	Thread 1/4 NPT F on cover flange. Material of cover flange SS316L. Allows mounting with a valve manifold. Not available for APRE-2000G/N	
	/GP or P.....	Addapter with G1/2" or M20 process connection.	
Accessories**	≤ /M20x1,5/Ø6.....	Adapter from Ø6mm elastic pipe for M20x1,5 M thread (only version with PCV process connection)	
	/RedSpaw C.....	Connector to weld impulse pipes dia. 12 and 14 mm, material 15HM. Only process connection C type.	
	/+VM-3/A.....	Assembled with a 3- way valve manifold ( further specification of manifold-see data sheet) . Only version with C type process connection.	
	/+VM-5/A.....	Assembled with a 5- way valve manifold ( further specification of manifold-see data sheet) Only version with C type process connection.	
**) more than one option is available			
Other specification	/.....	Description of required parameters	
The most typical specification is marked by "≤ " mark.			

**Example1:** Differential pressure transmitter , nominal measuring range –7...7mbar, stainless steel casing, calibrated – 0,5..1mbar, process connection PCV to elastic pipe ≤ 6mm plus two adapters from elastic pipe ≤ 6mm for M20x1.5 M thread

**APRE-2000G/PZ/-7≤7mbar/-0,5≤1mbar/PCV/ M201.5/≤ 6 (x2)**

**Example2:** Differential pressure transmitter , EEExia version, nominal measuring range 0..25mbar, housing with DIN43650 connector, calibrated 0..10mbar, process connection GP ( thread G1/2")

**APRE-2000G/EEEx/PD/0..25mbar/0..10mbar/GP**

**Example3:** Differential pressure transmitter , nominal measuring range –7...7mbar, calibrated 0...7mbar process connection PCV to elastic pipe ≤ 6mm, wall mounted version.

**APRE-2000G/N/-7≤7mbar/0≤7mbar/PCV/ M201.5/≤ 6 (x2)**