

LEVEL SWITCHES type ERH

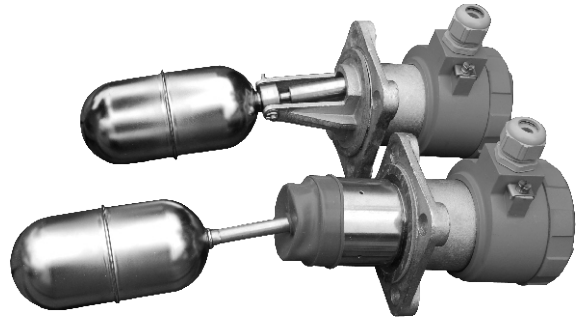

- ✓ Explosion proof version
- ✓ Wetted parts material 321SS
- ✓ Housing material: Aluminium or 321SS
- ✓ Housing protection IP66/68
- ✓ Nominal pressure 40bar
- ✓ Marine certificates (GL, DNV, LR, ABS, BV, PRS)



Application

Float level switches are used for point level detection of liquids in all type of vessels. Operation without external power, side or top mounting, wide temperature and pressure ranges, various process connections, stainless steel wetted parts, Ex version and marine certificates make it a universally applicable level switch. Level switches are available with floats in two sizes: Ø64.5 x 130mm or Ø52 x 162mm

Constructional versions

ERH-01-.... - Side mounted

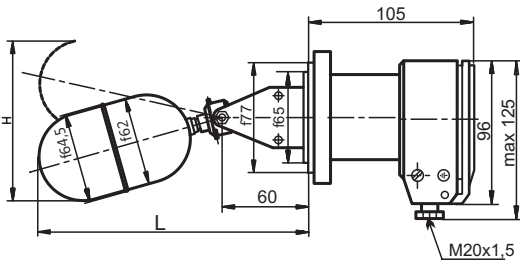

ERH-01- 4 - - Top mounted

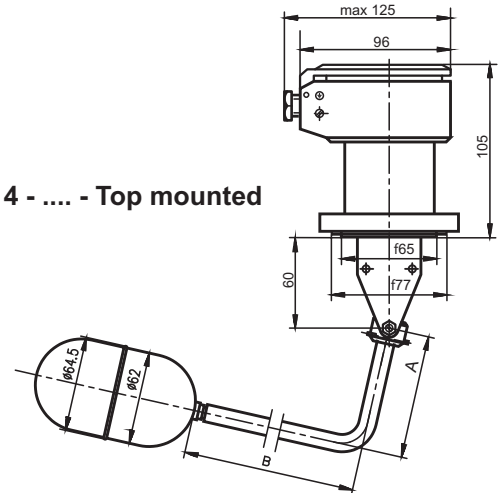

**ERH-02-.... - Side mounted
(version for contaminated liquids with protection sleeve)**

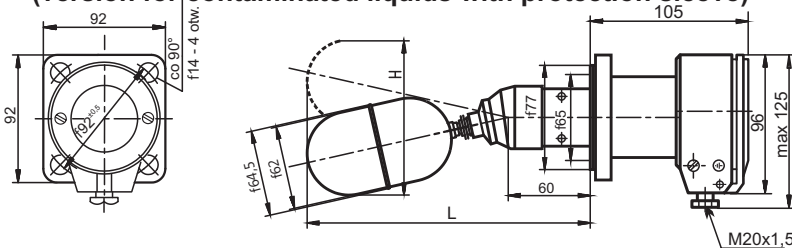

ERH-...-04; ERH-...-06; ERH-...-07

Symbol	Hmm	Lmm	Hysteresis "h"
- 1	120	190	10
- 2	140	230	20
- 3	150	255	30

ERH-...-16

Symbol	Hmm	Lmm	Hysteresis "h"
- 1	140	230	10
- 2	180	305	20
- 3	240	405	30

ERH-03-.... - Side mounted (version with adjustable hysteresis)

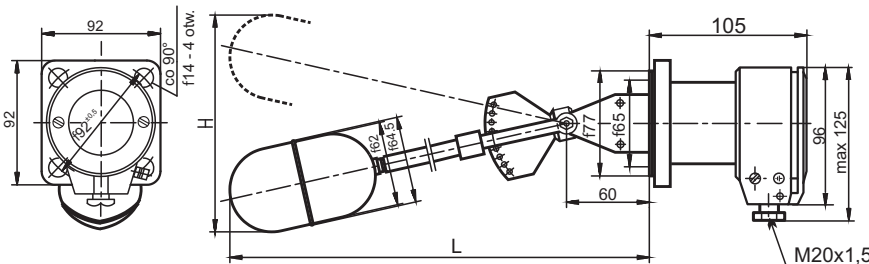

ERH-03-....

Symbol	Hmm	Lmm	Hysteresis "h"
- 1	680	510	from 100 to 400
- 2	450	380	from 50 to 250

ERH-04-.... - Top mounted version

Accessories

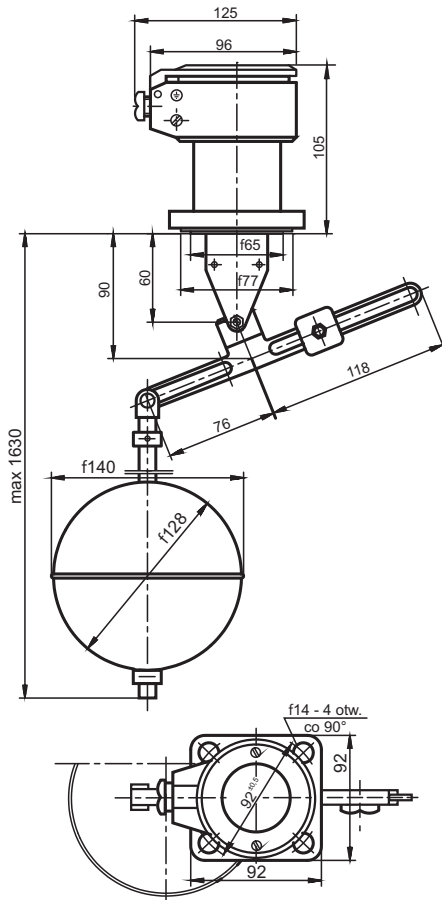

Counterflange type ER2-1646

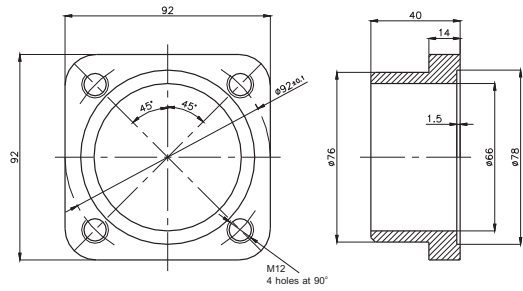

Tester ER3-1495

Tester is mounted between the unit and counter weight. Operation of the unit can be checked via tester without dismounting or filling.

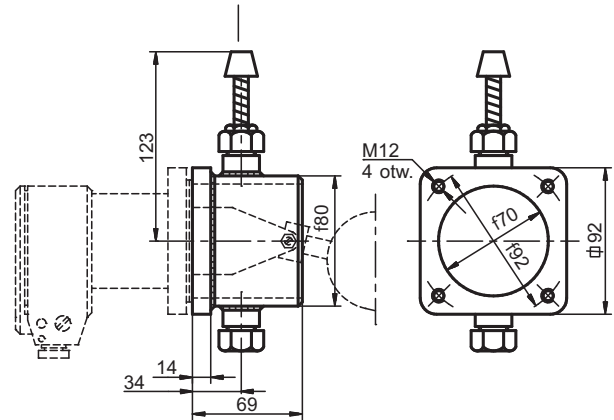

Electric circuit diagram

EHR-...-04,06, 07

ERH-...-16

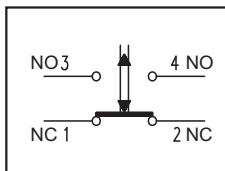

NC - closing contact
NO - opening contac

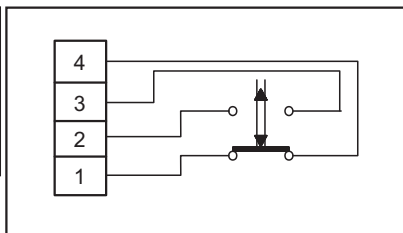

Assembly chamber type ER3-1631

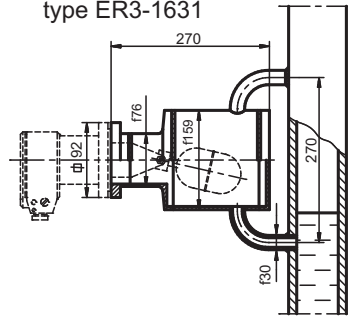

Tester ER3-1560

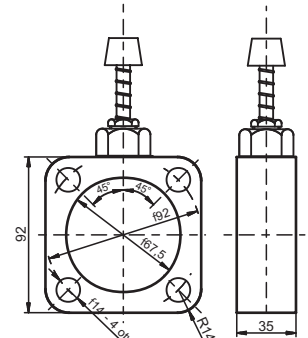

Technical Data

Parameters	ERH-01	ERH-02	ERH-03	ERH-04
Hysteresis of connection	10; 20; 30 mm	10; 20; 30 mm	100...400 mm (ERH-03-04) 50...250 mm (ERH-03-04) 50...400 mm (ERH-03-16)	32...1350 mm
Repeatability	±15%	±15%	±15%; ±5% dep.on hysteresis	±15%; ±2% dep.on hysteresis
Weight	2 kg	2,2 kg	2,4 kg	3,3 kg
Nominal pressure	40bar (2bar for ERH-...-07)			1,6 MPa
Permissible temp. of medium	250°C (ERH-01-04) (ERH-01-06) 100°C (ERH-01-16) 70°C (ERH-01-07)	200°C (ERH-01-04) (ERH-01-06) 100°C (ERH-02-16) 70°C (ERH-01-07)	250°C (ERH-01-04) (ERH-01-06) 100°C (ERH-01-16) 70°C (ERH-01-07)	
Exd protection (only ERH-...-16)	Ex II 1/2G c Ex de IIBT4			
Ambient temp.	-25°C...+70°C			
IP protection	IP 66			
Min. Medium density	0,6 x 10 ⁻³ kg/cm ³			

Electrical parameters

Level switches type: ERH -.....-04, ERH -.....-06

Min. voltage [V] and current [I]: 10V; 20mA

U [V]	DC		AC	
	I [A]	Life of connecting	I [A]	Life of connecting
48	4,0	0,06 x 10 ⁶	9,0	0,1 x 10 ⁶
110	1,0			
220	0,6			
400	X	X		

Level switches type: ERH -.....-16 - explosion proof version

Min. voltage [V] and current [I]: 10V; 20mA

U [V]	DC		AC	
	I [A]	Life of connecting	I [A]	Life of connecting
24	2,5	30 x 10 ³	X	85 x 10 ³
110	0,6		2,5	
220	0,4		2,5	

Level switches type: ERH -.....-07 version with IP68

Min. voltage [V] and current [I]: 10V; 20mA

U [V]	DC		AC	
	I [A]	Life of connecting	I [A]	Life of connecting
24	2,5	30 x 10 ³	X	85 x 10 ³

Ordering procedure

Model	Code		Description
ERH			Level switch
Constructional version	-01		Standard version
	-02		Version for contaminated liquids with protection sleeve
	-03		Version with adjustable hysteresis
	-04		Top mounting version
Version/certificate	-04		IP66, standard version
	-04K		IP66, standard version, all wetted parts SS (incl. housing)
	-06		IP66, marine approval, hygienic approval
	-07		Submersible version IP68
	-07K		Submersible version IP68, all wetted parts SS (incl. housing)
	-16		IP66, explosion proof version
Floating arm length/hysteresis	Options for ERH-01 and ERH-02 only	-1	Hysteresis h=10mm
		-2	Hysteresis h=20mm
		-3	Hysteresis h=30mm
		-4-0	Floating arm length A=125mm, B=125mm
		-4-1	Floating arm length A=185mm, B=80mm
		-4-2	Floating arm length A=250mm, B=125mm
		-4-3	Floating arm length A=140mm, B=120mm
		-4-4	Floating arm length A=100mm, B=120mm
		-4-5	Floating arm length A=120mm, B=80mm
		-4-6	Floating arm length A=150mm, B=80mm
	-4-Y	Floating arm length on request. Please specify A and B	
	Options for ERH-03 only	-1	Adjustable hysteresis min 100mm, max 400mm
		-2	Adjustable hysteresis min 50mm, max 250mm
	Cable		-1
		-2	With cable L= ...m (standard 3m, other length on request,)
Accessories		/ER3-1560	Testing equipment (standard version)
		/ER3-1495	Testing equipment to weld in a tank
		/ER2-1646	Counter flange
		/ER3-1631	Assembly chamber
		/DN80	Process connection flange DN80
		/ANSI 3"	Process connection flange ANSI 3" 150LB